



PS 1510

BOITIER D'ALARME ALARM BOX

I - DESCRIPTION

The **PS 1510** is an intercom substation. It allows surveillance of locals. Proceed to the call by pressing the push-button. The cabinet made out of metal and red painted is wall mounted and provided with 2 cable seals to connect wires.

I - DESCRIPTION

The **PS 1510** is an intercom substation. It allows surveillance of locals. Proceed to the call by pressing the push-button. The cabinet made out of metal and red painted is wall mounted and provided with 2 cable seals to connect wires.

II - CARACTÉRISTIQUES TECHNIQUES

- Impédance 50 Ω
- Puissance 1 W
- Appel vers le poste chef par enfoncement de la plaquette déformable
- Retour à la position initiale de la plaquette déformable, comme suit :
 - ① Insérer la clé fournie dans la découpe en V (Fig. III)
 - ② Faire lever vers le bas pour réarmer la plaquette
- Contacts secs I max = 10 mA
V max = 25V
- Couleur rouge (RAL 3020)
- Peinture époxy
- Dimensions (LxPxH) 93 x 38 x 143mm (Fig. I)
- Poids 0,5 kg

II - TECHNICAL SPECIFICATIONS

- Impedance 50 Ω
- Power 1 W
- Call to a master station by pressing on the flexible call plate
- The flexible call plate returns to its initial position, as follows :
 - ① Insert the key into the cut-out (Fig. III)
 - ② Lever to fit up again
- Dry contacts I max = 10 mA
V max = 25V
- Colour red(RAL 3020)
- Epoxy paint
- Dimensions (WxDxH) 93 x 38 x 143mm (Fig. I)
- Weight 0,5 kg

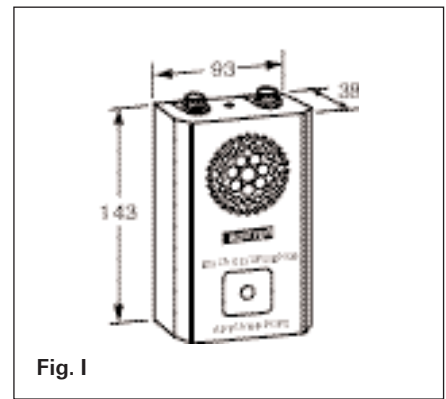

Fig. I

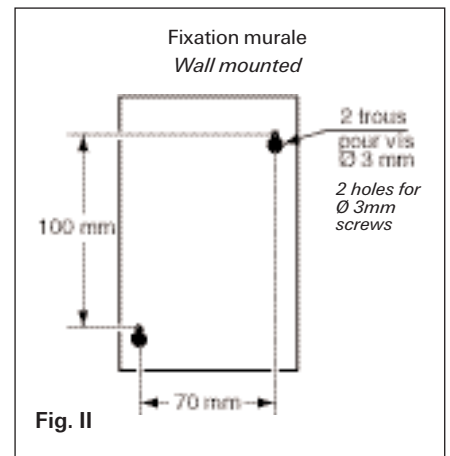

Fig. II

III - CABLAGE

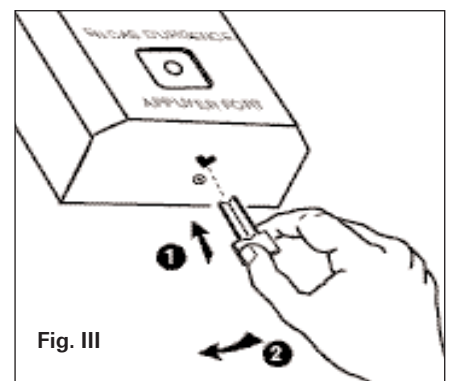
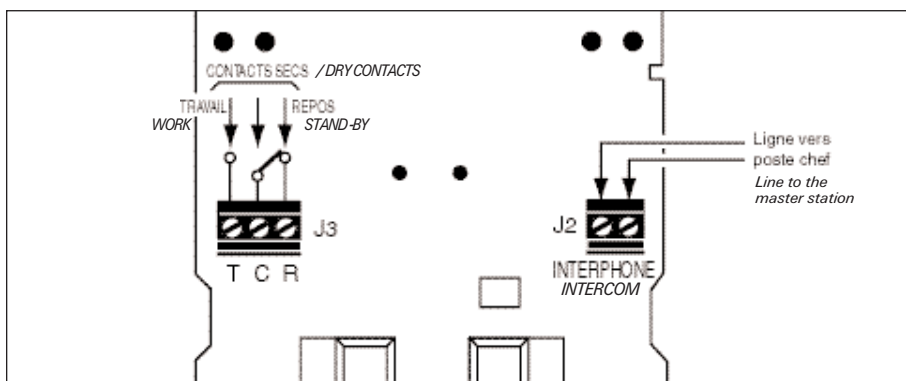

Fig. III

