

RB-5019

Speakers

Projector loudspeaker



- High intelligibility
- Protection index IP 55
- Multipurpose and inconspicuous
- Easy and quick installation

The **RB-5019** is a 6W projector-type speaker fitted with a dual cone loudspeaker.

Its fixing device makes its orientation easy and guarantees a simple and quick installation : wall-mounting or ceiling-mounting.

Its body out of ABS is perfect for harsh environments and ensures an enduring and resistant installation. It can thus be installed in any type of environment.

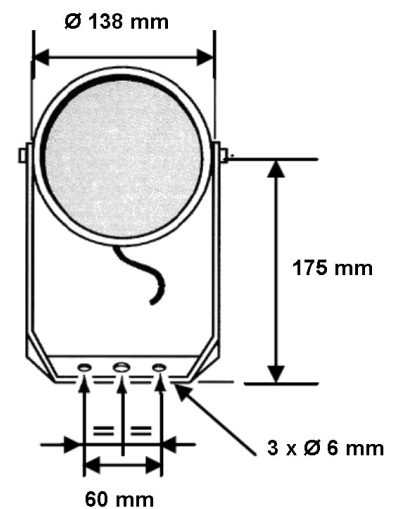

Caractéristiques

Loudspeaker		Dual cone
Powers	Nominal 6W	6 - 3 - 1,5W
Frequency band		180Hz - 19kHz
SPL	92,5dBA/1W/1m	100dBA/6W/1m
Directivity -6dB		110°
Dimensions		138 x 205 mm
Color	White	RAL 9016
Material		ABS
Weight		1,5Kg

Applications

Humid places..... 

Music..... 

Speech..... 

▶ Campings

▶ Corridors

▶ Technical rooms

▶ Car parks

▶ Railways platforms

▶ Urban road

